

Section 3

Non-Determinism, Regular Expressions, and Kleene's Theorem

- 1 Non-Determinism, Regular Expressions, and Kleene's Theorem
 - Examples
 - Allowing \wedge -transitions
 - Definitions
 - Making the automaton deterministic

Non-determinism:

possibly many computations on given input

accept input when at least one of these computations accepts.

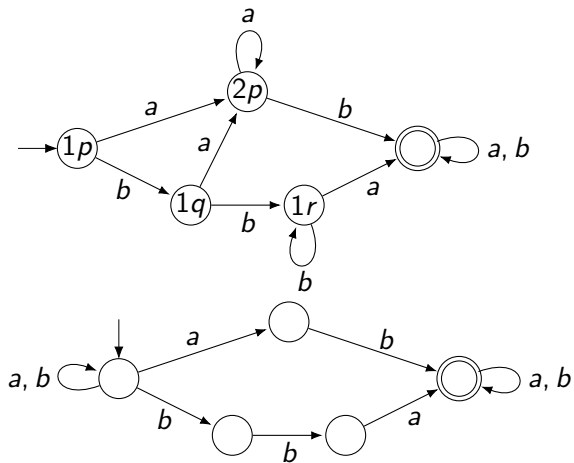

[M] see \leftrightarrow E.2.18 (product construction)

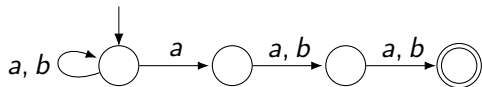

Also \hookrightarrow deterministic

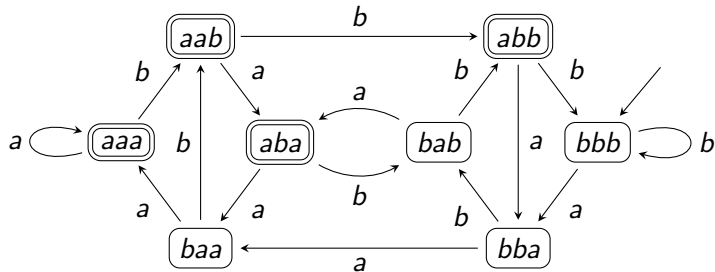

$n + 1$ versus 2^n states.

[M] E. 2.24

From lecture 3:

$$L = \{aa, aab\}^* \{b\}$$

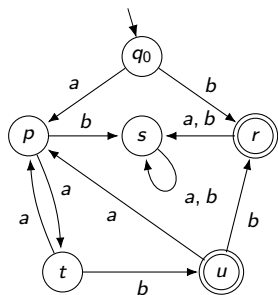

[M] E 2.22

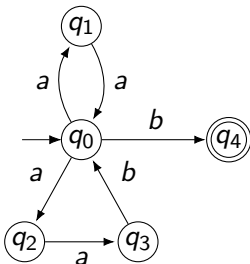

$x = aaaabaab$

[M] E 3.6. also \leftrightarrow E 2.22

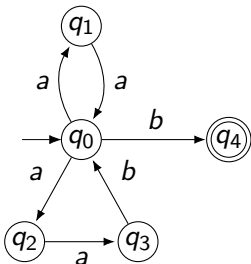

$x = aaaabaab$

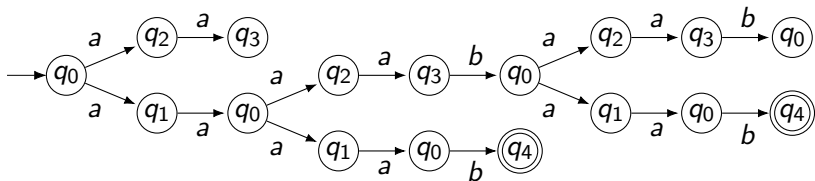

[M] E 3.6. also \leftrightarrow E 2.22

$$L = \{aab\}^* \{a, aba\}^*$$

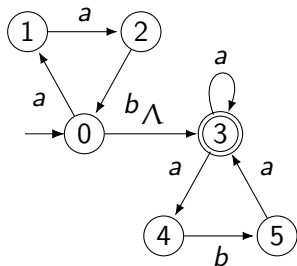

NFA

[M] E 3.9

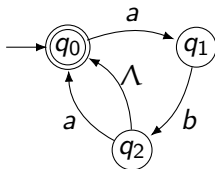
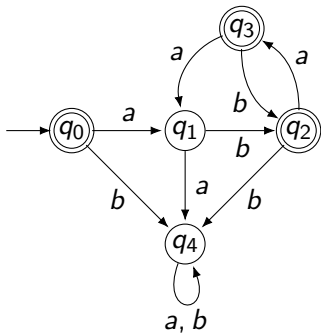

Computation tree when Λ 's are around

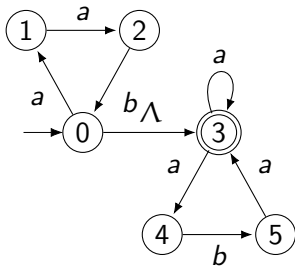

$x = aababa$

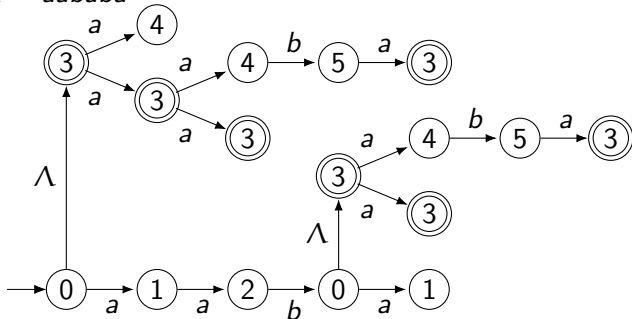

From lecture 2:

Definition (FA)

[deterministic] finite automaton 5-tuple $M = (Q, \Sigma, q_0, A, \delta)$,

- Q finite set *states*;
- Σ finite *input alphabet*;
- $q_0 \in Q$ *initial state*;
- $A \subseteq Q$ *accepting states*;
- $\delta : Q \times \Sigma \rightarrow Q$ *transition function*.

[M] D 2.11 Finite automaton

[L] D 2.1 Deterministic finite accepter, has 'final' states

$\delta : Q \times \Sigma \rightarrow Q$

5-tuple $M = (Q, \Sigma, q_0, A, \delta)$

Definition (\hookrightarrow FA)

[deterministic] finite automaton

– $\delta : Q \times \Sigma \rightarrow Q$ *transition function*;

Definition (NFA)

nondeterministic finite automaton (with \wedge -transitions)

– $\delta : \dots$

5-tuple $M = (Q, \Sigma, q_0, A, \delta)$

Definition (\hookrightarrow FA)

[deterministic] finite automaton

– $\delta : Q \times \Sigma \rightarrow Q$ *transition function*;

Definition (NFA)

nondeterministic finite automaton (with Λ -transitions)

– $\delta : Q \times (\Sigma \cup \{\Lambda\}) \rightarrow \dots$

Example

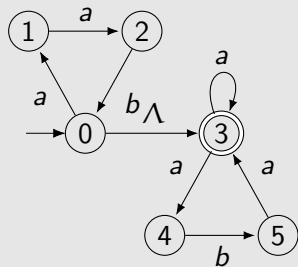
$$\{aab\}^*\{a, aba\}^*$$

NFA

δ	Λ	a	b
0	{3}	{1}	\emptyset
3	\emptyset	{3, 4}	\emptyset

5-tuple $M = (Q, \Sigma, q_0, A, \delta)$

Definition (\hookrightarrow FA)

[deterministic] finite automaton

– $\delta : Q \times \Sigma \rightarrow Q$ transition function;

Definition (NFA)

nondeterministic finite automaton (with Λ -transitions)

– $\delta : Q \times (\Sigma \cup \{\Lambda\}) \rightarrow 2^Q$

Where 2^Q the set of all subsets of Q :

$$2^Q = \{S \mid S \subseteq Q\}$$

Extended transfer function, without Λ -transitions

Extend δ to subsets P :

$$\delta(P, \sigma) = \bigcup_{p \in P} \delta(p, \sigma) = \{q \in Q \mid q \in \delta(p, \sigma) \text{ for some } p \in P\}.$$

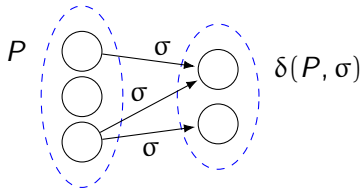

$\delta^*(q, x) \dots$

Extended transfer function, without Λ -transitions

Extend δ to subsets P :

$$\delta(P, \sigma) = \bigcup_{p \in P} \delta(p, \sigma) = \{q \in Q \mid q \in \delta(p, \sigma) \text{ for some } p \in P\}.$$

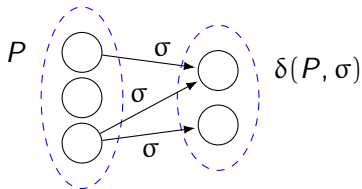

$$\delta^*(q, \Lambda) = \{q\}$$

$$\delta^*(q, y\sigma) = \delta(\delta^*(q, y), \sigma)$$

Now, with Λ -transitions: $\delta^*(q, x) \dots$

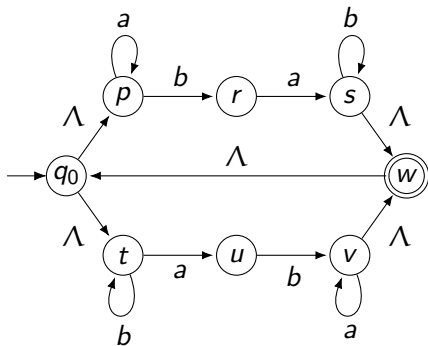

Λ

$$\delta^*(q_0, \Lambda) = \dots$$

$\Lambda \cdot a$

$$\delta^*(q_0, a) = \dots$$

$a \cdot b$

$$\delta^*(q_0, ab) = \dots$$

$ab \cdot a$

$$\delta^*(q_0, aba) = \dots$$

[M] E 3.15

NFA $M = (Q, \Sigma, q_0, A, \delta)$ $S \subseteq Q$

Definition

- $S \subseteq \Lambda(S)$
- $q \in \Lambda(S)$, then $\delta(q, \Lambda) \subseteq \Lambda(S)$

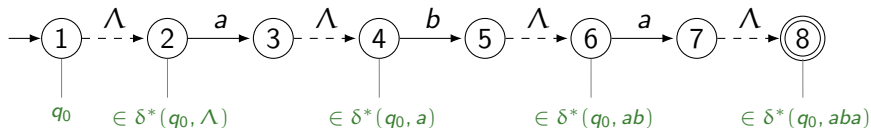

Definition

- $\delta^*(q, \Lambda) = \Lambda(\{q\})$ $q \in Q$
- $\delta^*(q, y\sigma) = \Lambda(\delta(\delta^*(q, y), \sigma))$ $q \in Q, y \in \Sigma^*, \sigma \in \Sigma$

[M] D 3.13 & 3.14

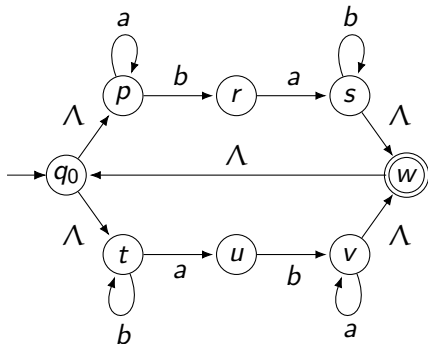

Λ

$$\Lambda(\{q_0\}) = \{q_0, p, t\}$$

$$\delta^*(q_0, \Lambda) = \{q_0, p, t\}$$

$\Lambda \cdot a$

$$\delta(\{q_0, p, t\}, a) = \{p, u\}$$

$$\delta^*(q_0, a) = \Lambda(\{p, u\}) = \{p, u\}$$

$a \cdot b$

$$\delta(\{p, u\}, b) = \{r, v\}$$

$$\delta^*(q_0, ab) = \Lambda(\{r, v\}) = \{r, v, w, q_0, p, t\}$$

$ab \cdot a$

$$\delta(\{r, v, w, q_0, p, t\}, a) = \{s, v, p, u\}$$

$$\delta^*(q_0, aba) = \Lambda(\{s, v, p, u\}) = \{s, w, q_0, p, t, v, u\}$$

[M] E 3.15

NFA $M = (Q, \Sigma, q_0, A, \delta)$

Theorem

$q \in \delta^*(p, x)$ iff there is a path in [the transition graph of] M from p to q with label x (possibly including Λ -transitions).

$\delta^*(q_0, x) = \emptyset$ no path for x from initial state

Definition

A string $x \in \Sigma^*$ is accepted by $M = (Q, \Sigma, q_0, A, \delta)$ if $\delta^*(q_0, x) \cap A \neq \emptyset$.
The *language* $L(M)$ *accepted* by M is the set of all strings accepted by M .

[M] D 3.14 [L] D 2.2

$$L = \{aab\}^* \{a, aba\}^*$$

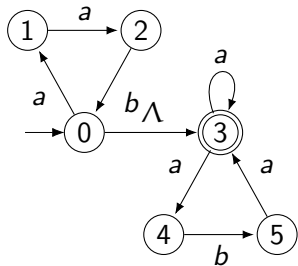
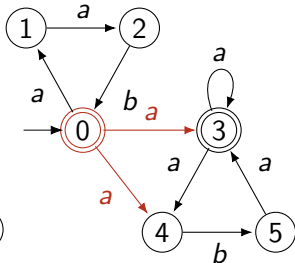
NFA- Λ 

NFA

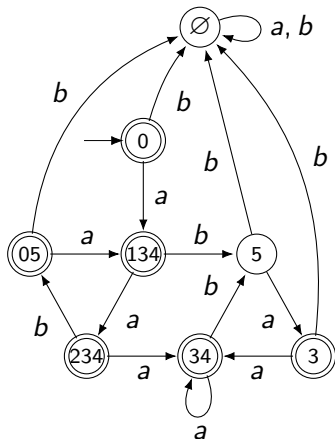

FA

Theorem

For every language $L \subseteq \Sigma^$ accepted by an NFA $M = (Q, \Sigma, q_0, A, \delta)$, there is an NFA M_1 with no Λ -transitions that also accepts L .*

[M] T 3.17

The precise inductive proof of this result does not have to be known for the exam. However, the construction in the next slides has to be known.

Construction: removing Λ -transitions

Different from book!

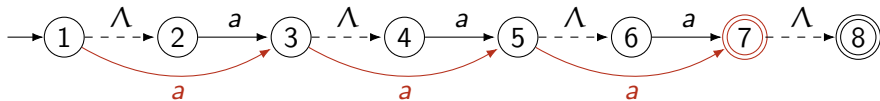

Example

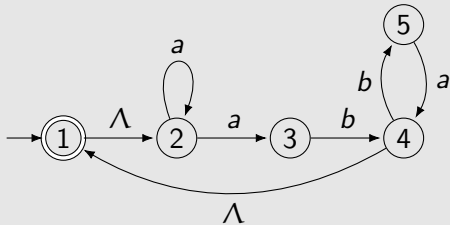

[M] E 3.19 **but fewer edges!**

Construction: removing Λ -transitions

Different from book!

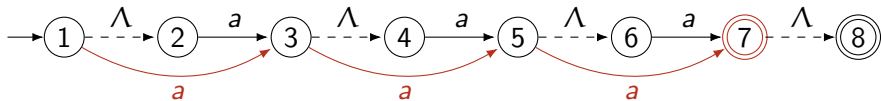

Example

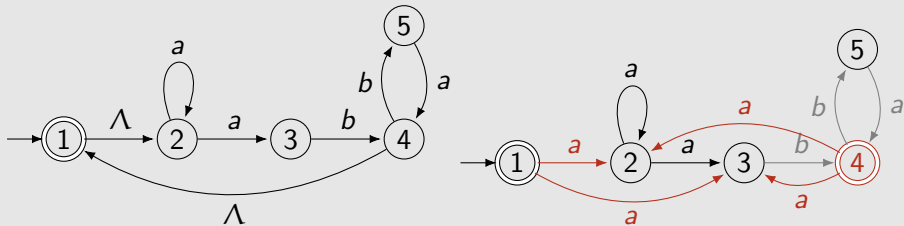

[M] E 3.19 but fewer edges!

Different from book!

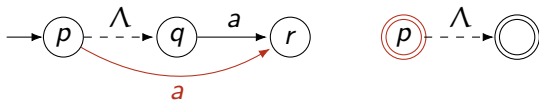
 Λ -removalNFA $M = (Q, \Sigma, q_0, A, \delta)$ construct NFA $M_1 = (Q, \Sigma, q_0, A_1, \delta_1)$ without Λ -transitions

- whenever $q \in \Lambda_M(\{p\})$ and $r \in \delta(q, a)$, add r to $\delta_1(p, a)$
- whenever $\Lambda_M(\{p\}) \cap A \neq \emptyset$, add p to A_1 .

In particular,

- non- Λ -transitions are maintained
- $A \subseteq A_1$

Construction: removing Λ -transitions

Different from book!

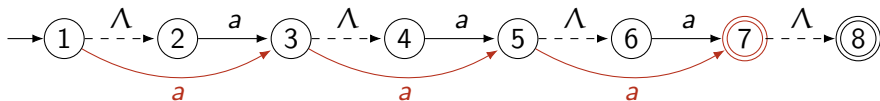

Example

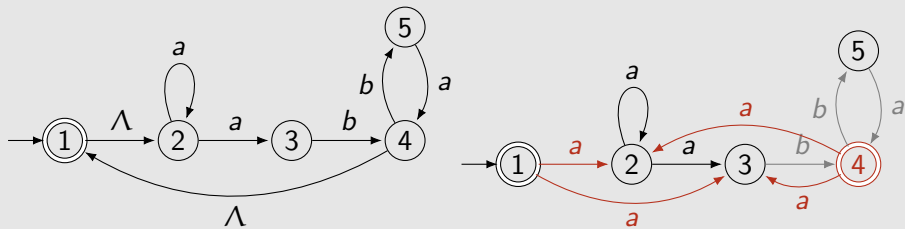

Construction book: $\delta_1(p, \sigma) = \delta^*(p, \sigma) \quad \forall p \in Q, \forall \sigma \in \Sigma$

Accepting states: $A \cup \{q_0\}$ if $\Lambda \in L$, A otherwise

[M] E 3.19

$$L = \{aab\}^* \{a, aba\}^*$$

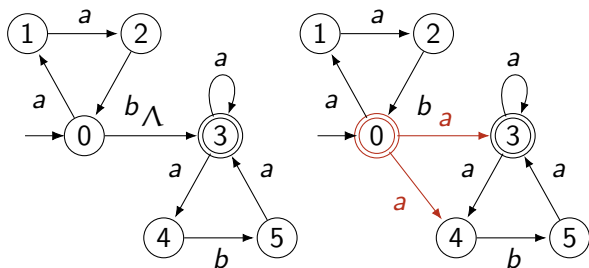

NFA example 1) removing Λ -transitions

Self-study

$$\{a\}^* [\{ab\}^* \{b\} \cup \{b\}^* \{a\}]$$

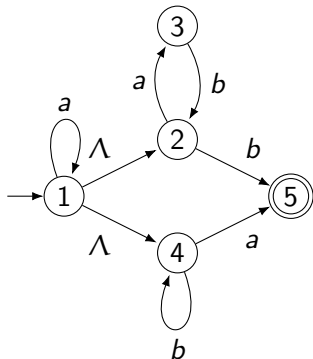

q	$\delta(q, a)$	$\delta(q, b)$	$\delta(q, \Lambda)$	$\Lambda(\{q\})$
1	1	—	2, 4	1, 2, 4
2	3	5	—	2
3	—	2	—	3
4	5	4	—	4
5	—	—	—	5

[M] E 3.23



NFA example 1) removing Λ -transitions

Self-study

$\{a\}^* [\{ab\}^* \{b\} \cup \{b\}^* \{a\}]$

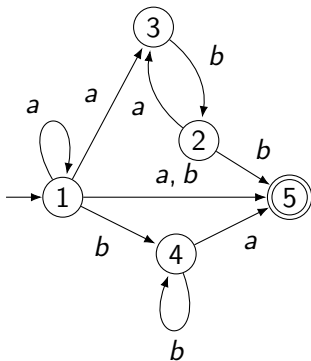
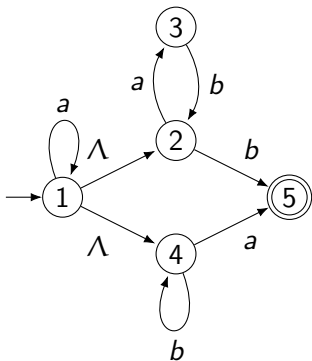

[M] E 3.23 **but fewer edges!**

Theorem

For every language $L \subseteq \Sigma^$ accepted by an NFA $M = (Q, \Sigma, q_0, A, \delta)$ without Λ -transitions, there is an FA M_1 that also accepts L .*

[M] T 3.18

The precise inductive proof of this result does not have to be known for the exam. However, the construction in the next slides has to be known.

Folding the computation tree

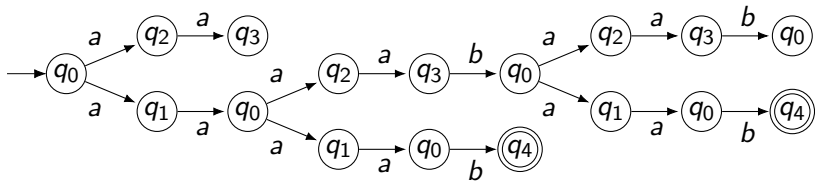

$\{q_0\}$ $\{q_1, q_2\}$ $\{q_0, q_3\}$ $\{q_1, q_2\}$ $\{q_0, q_3\}$ $\{q_0, q_4\}$ $\{q_1, q_2\}$ $\{q_0, q_3\}$ $\{q_0, q_4\}$

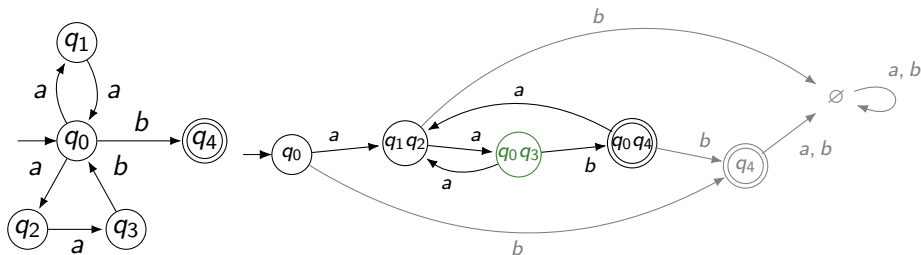

[M] E 3.6 and E 3.21

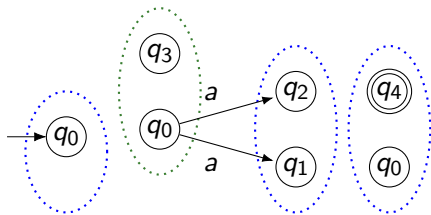

Subset construction

NFA $M = (Q, \Sigma, q_0, A, \delta)$ without \wedge -transitions

construct FA $M_1 = (Q_1, \Sigma, \delta_1, q_1, A_1)$

- $Q_1 = 2^Q$, i.e., sets of states of M
- $q_1 = \{q_0\}$
- $A_1 = \{q \in Q_1 \mid q \cap A \neq \emptyset\}$
- $\delta_1(q, \sigma) = \bigcup_{p \in q} \delta(p, \sigma) \quad \forall q \in Q_1, \forall \sigma \in \Sigma$

[M] Th 3.18

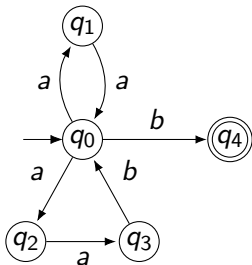

q	$\delta(q, a)$	$\delta(q, b)$
0	1, 2	4
1	0	—
2	3	—
3	—	0
4	—	—

[M] E 3.21. also \leftrightarrow E 3.6

$$L = \{aa, aab\}^*\{b\}$$

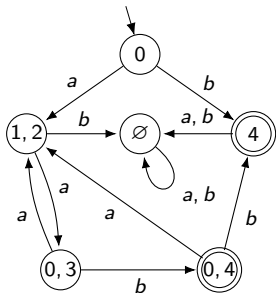

Minimal this time, yet not always

[M] E 3.21. also \leftrightarrow E 3.6

Once more $\{aa, aba\}^* \{b\}$

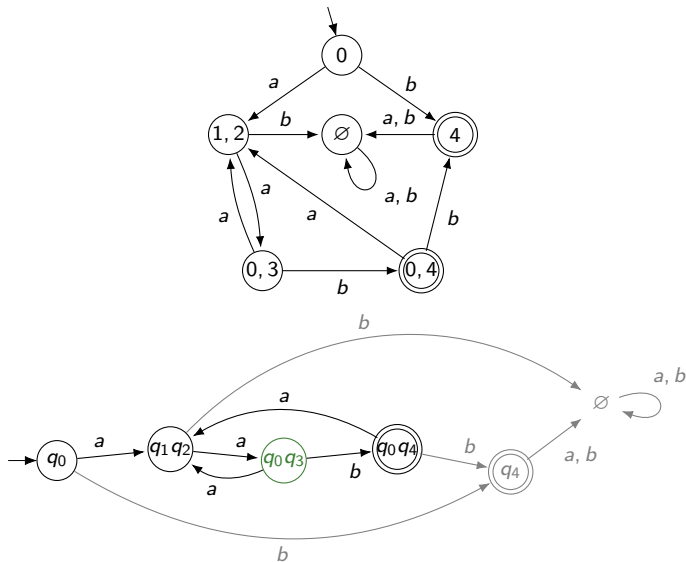

[M] E 3.6 and E 3.21

ABOVE

The subset construction (or powerset construction) can be used to transform a non-deterministic finite state automaton (without Λ) into an equivalent deterministic automaton. The states of the new automaton consist of sets of states of the original automaton (hence powerset). The set collects all possible states that the original automaton could have ended in with the same input.

Note that the constructed automaton may be exponential in size compared to the nondeterministic one.

REFERENCE

M.O. Rabin, D. Scott. Finite automata and their decision problems. IBM Journal of Research and Development. 3 (2): 114–125, 1959. doi:[10.1147/rd.32.0114](https://doi.org/10.1147/rd.32.0114)

BELOW

Unreachable states can be omitted.

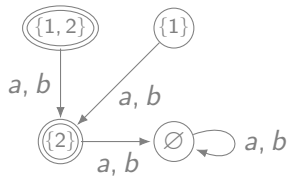
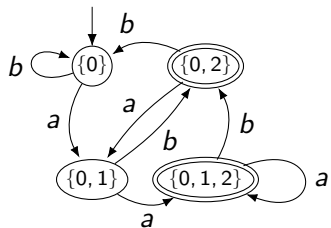
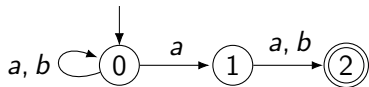

also \leftrightarrow 3rd from the end

Example: subset construction

Seen previously:

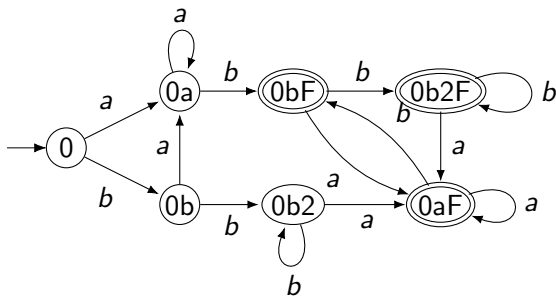
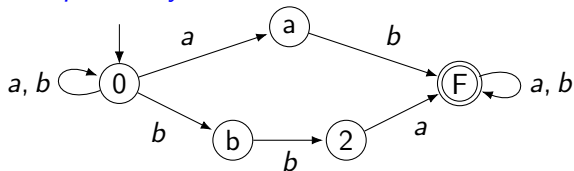

[M] language from \leftrightarrow E 2.18

Example

$L_3 = \{ x \in \{a, b\}^* \mid x \text{ contains the substring } abbaab \}$

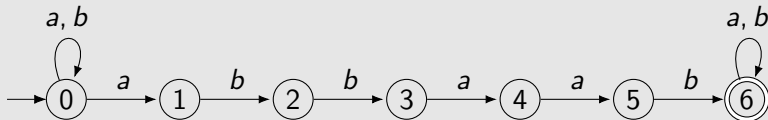

[M] \leftrightarrow E. 2.5 (deterministic)

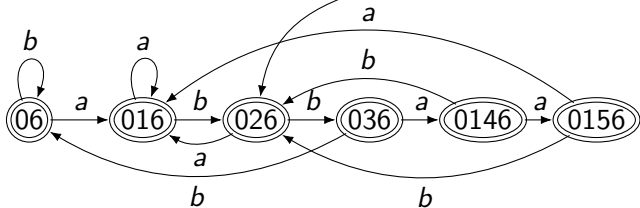
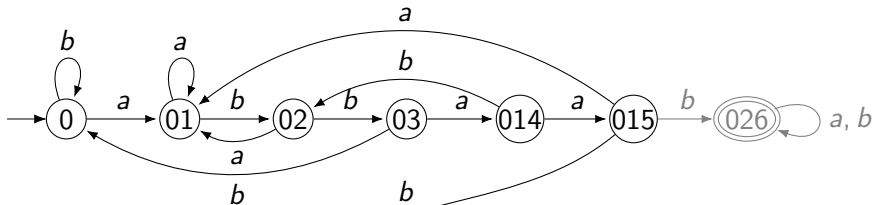
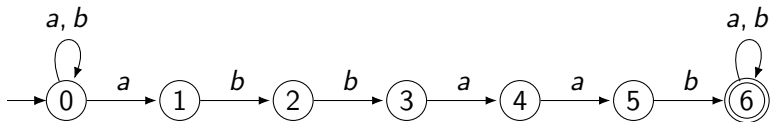

ABOVE

Illustration.

The determinization, i.e., make deterministic, algorithm for the non-deterministic automaton for “has substring x ” will always generate two copies of x . In the last copy all nodes are accepting, and they can be reduced to one node.

Example ($n = 4$)

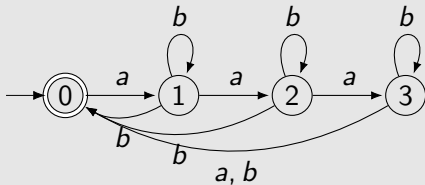

All 2^n subsets are reachable, nonequivalent, states.

ABOVE

Theoretically, the subset construction used on a set Q with n nodes constructs an automaton with state set 2^Q with 2^n nodes. In practice however, not all nodes are really necessary.

Usually not all nodes are reachable, and we omit those from the construction.

Sometimes nodes can be joined because they are equivalent.

This worst-case example however needs all nodes. So the determinization algorithm applied to a finite state automaton in the worst case will blow-up the original nondeterministic automaton exponentially in size.

NFA example 2) subset construction

Self-study

$$\{a\}^* [\{ab\}^* \{b\} \cup \{b\}^* \{a\}]$$

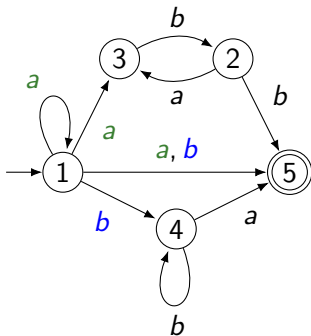

q	$\delta(q, a)$	$\delta(q, b)$
1	1, 3, 5	4, 5
2	3	5
3	—	2
4	5	4
5	—	—

[M] E 3.23 ctd.

NFA example 2) subset construction

Self-study

$$\{a\}^* [\{ab\}^* \{b\} \cup \{b\}^* \{a\}]$$

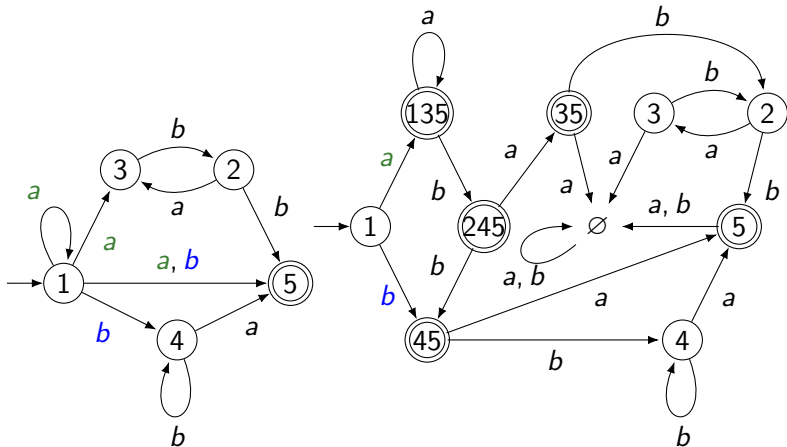

[M] E 3.23 ctd.

Construct an equivalent FA, applying the appropriate algorithms.

