

Huiswerkopgave 2 nakijken
Huiswerkopgave 3 inleveren
Huiswerkopgave 4 lanceren

$S \rightarrow abc$

Bottom-up = shift-reduce

$$AeqB = \{ x \in \{a, b\}^* \mid n_a(x) = n_b(x) \}$$

$$S \rightarrow \Lambda \mid aB \mid bA$$

$$A \rightarrow aS \mid bAA$$

$$B \rightarrow bS \mid aBB$$

	stack ^r	input	
q_0	Z_0	<i>aababb</i>	shift <i>a</i>
q_0	$Z_0 a$	<i>a ababb</i>	shift <i>a</i>
q_0	$Z_0 aa$	<i>aa babb</i>	shift <i>b</i>
q_0	$Z_0 aab$	<i>aab abb</i>	1 : $S \rightarrow \Lambda$
q_0	$Z_0 aabS$	<i>aab abb</i>	2 : $B \rightarrow bS$
q_0	$Z_0 aaB$	<i>aab abb</i>	shift <i>a</i>
q_0	$Z_0 aaBa$	<i>aaba bb</i>	shift <i>b</i>
q_0	$Z_0 aaBab$	<i>aabab b</i>	3 : $S \rightarrow \Lambda$
q_0	$Z_0 aaBabS$	<i>aabab b</i>	4 : $B \rightarrow bS$
q_0	$Z_0 aaBaB$	<i>aabab b</i>	shift <i>b</i>
q_0	$Z_0 aaBaBb$	<i>aababb</i>	5 : $S \rightarrow \Lambda$
q_0	$Z_0 aaBaBbS$	<i>aababb</i>	6 : $B \rightarrow bS$
q_0	$Z_0 aaBaBB$	<i>aababb</i>	7 : $B \rightarrow aBB$
q_0	$Z_0 aaBB$	<i>aababb</i>	8 : $B \rightarrow aBB$
q_0	$Z_0 aB$	<i>aababb</i>	9 : $S \rightarrow aB$
q_0	$Z_0 S$	<i>aababb</i>	
q_1	Z_0	<i>aababb</i>	
q_2	Z_0	<i>aababb</i>	

Bottom-up = shift-reduce

$$AeqB = \{ x \in \{a, b\}^* \mid n_a(x) = n_b(x) \}$$

$$S \rightarrow \Lambda \mid aB \mid bA$$

$$A \rightarrow aS \mid bAA$$

$$B \rightarrow bS \mid aBB$$

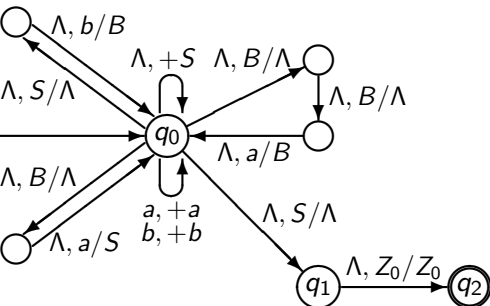

+ states/transitions for other productions

	stack ^r	input	
q ₀	Z ₀	aababb	shift a
q ₀	Z ₀ a	a ababb	shift a
q ₀	Z ₀ aa	aa babb	shift b
q ₀	Z ₀ aab	aab abb	1 : S → Λ
q ₀	Z ₀ aabS	aab abb	2 : B → bS
q ₀	Z ₀ aaB	aab abb	shift a
q ₀	Z ₀ aaBa	aaba bb	shift b
q ₀	Z ₀ aaBab	aabab b	3 : S → Λ
q ₀	Z ₀ aaBabS	aabab b	4 : B → bS
q ₀	Z ₀ aaBaB	aabab b	shift b
q ₀	Z ₀ aaBaBb	aababb	5 : S → Λ
q ₀	Z ₀ aaBaBbS	aababb	6 : B → bS
q ₀	Z ₀ aaBaBB	aababb	7 : B → aBB
q ₀	Z ₀ aaBB	aababb	8 : B → aBB
q ₀	Z ₀ aB	aababb	9 : S → aB
q ₀	Z ₀ S	aababb	
q ₁	Z ₀	aababb	
q ₂	Z ₀	aababb	

Bottom-up = shift-reduce

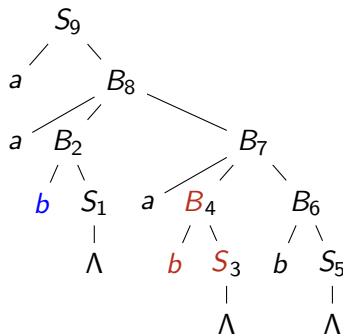

postorder: rightmost, in reverse
 $S \xRightarrow{9} aB \Rightarrow_8 aaBB \Rightarrow_7 aaBaBB \Rightarrow_6 aaBaBbS \Rightarrow_5 aaBaBb \Rightarrow_4 aaBabSb \Rightarrow_3 aaBabb \Rightarrow_2 aabSabb \Rightarrow_1 aababb$

	stack ^r	input	
q_0	Z_0	<i>aababb</i>	shift <i>a</i>
q_0	$Z_0 a$	<i>a ababb</i>	shift <i>a</i>
q_0	$Z_0 aa$	<i>aa babb</i>	shift <i>b</i>
q_0	$Z_0 aab$	<i>aab abb</i>	1 : $S \rightarrow \Lambda$
q_0	$Z_0 aabS$	<i>aab abb</i>	2 : $B \rightarrow bS$
q_0	$Z_0 aaB$	<i>aab abb</i>	shift <i>a</i>
q_0	$Z_0 aaBa$	<i>aaba bb</i>	shift <i>b</i>
q_0	$Z_0 aaBab$	<i>aabab b</i>	3 : $S \rightarrow \Lambda$
q_0	$Z_0 aaBaS$	<i>aabab b</i>	4 : $B \rightarrow bS$
q_0	$Z_0 aaBaB$	<i>aabab b</i>	shift <i>b</i>
q_0	$Z_0 aaBaBb$	<i>aababb</i>	5 : $S \rightarrow \Lambda$
q_0	$Z_0 aaBaBbS$	<i>aababb</i>	6 : $B \rightarrow bS$
q_0	$Z_0 aaBaBB$	<i>aababb</i>	7 : $B \rightarrow aBB$
q_0	$Z_0 aaBB$	<i>aababb</i>	8 : $B \rightarrow aBB$
q_0	$Z_0 aB$	<i>aababb</i>	9 : $S \rightarrow aB$
q_0	$Z_0 S$	<i>aababb</i>	
q_1	Z_0	<i>aababb</i>	
q_2	Z_0	<i>aababb</i>	

Bottom-up = shift-reduce

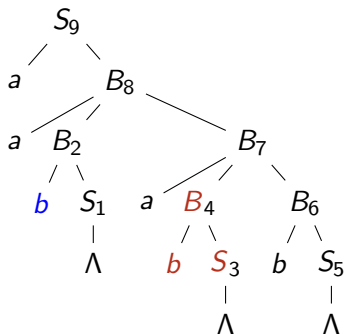

postorder: rightmost, in reverse
 $S \xRightarrow{9} aB \Rightarrow_8 aaBB \Rightarrow_7 aaBaBB \Rightarrow_6$
 $aaBaBbS \Rightarrow_5 aaBaBb \Rightarrow_4 aaBabSb$
 $\Rightarrow_3 aaBabb \Rightarrow_2 aabSabb \Rightarrow_1 aababb$

	stack ^r	input	
q_0	Z_0	<i>aababb</i>	shift <i>a</i>
q_0	$Z_0 a$	<i>a ababb</i>	shift <i>a</i>
q_0	$Z_0 aa$	<i>aa babb</i>	shift <i>b</i>
q_0	$Z_0 aab$	<i>aab abb</i>	1 : $S \rightarrow \Lambda$
q_0	$Z_0 aabS$	<i>aab abb</i>	2 : $B \rightarrow bS$
q_0	$Z_0 aaB$	<i>aab abb</i>	shift <i>a</i>
q_0	$Z_0 aaBa$	<i>aaba bb</i>	shift <i>b</i>
q_0	$Z_0 aaBab$	<i>aabab b</i>	3 : $S \rightarrow \Lambda$
q_0	$Z_0 aaBabS$	<i>aabab b</i>	4 : $B \rightarrow bS$
q_0	$Z_0 aaBaB$	<i>aabab b</i>	shift <i>b</i>
q_0	$Z_0 aaBaBb$	<i>aababb</i>	5 : $S \rightarrow \Lambda$
q_0	$Z_0 aaBaBbS$	<i>aababb</i>	6 : $B \rightarrow bS$
q_0	$Z_0 aaBaBB$	<i>aababb</i>	7 : $B \rightarrow aBB$
q_0	$Z_0 aaBB$	<i>aababb</i>	8 : $B \rightarrow aBB$
q_0	$Z_0 aB$	<i>aababb</i>	9 : $S \rightarrow aB$
q_0	$Z_0 S$	<i>aababb</i>	
q_1	Z_0	<i>aababb</i>	
q_2	Z_0	<i>aababb</i>	

ABOVE

To write down the construction of the shift-reduce PDA for a given CFG, we have two technical problems.

Consider a production $A \rightarrow \alpha$

First the stack (in standard notation) now contains the string α in reverse.

Second, we pop α , that is, several symbols, rather than exactly one. This can be simulated by popping the symbols one-by-one, using separate instructions.

shift $\delta(q_0, \sigma, X) = \{(q_0, \sigma X)\}$ for $\sigma \in \Sigma, X \in \Gamma$
reduce $\delta^*(q_0, \Lambda, \alpha^r) \ni (q_0, A)$ for $A \rightarrow \alpha$ in P

Definition

The Nondeterministic Bottom-Up PDA $NB(G)$

Let $G = (V, \Sigma, S, P)$ be a context-free grammar.

The nondeterministic bottom-up PDA corresponding to G is

$NB(G) = (Q, \Sigma, \Gamma, q_0, Z_0, A, \delta)$, defined as follows:

Q contains the initial state q_0 , the state q_1 , and the (only) accepting state q_2 , together with other states to be described shortly.

$\Gamma = \dots$

[M] D 5.22

Definition

The Nondeterministic Bottom-Up PDA $NB(G)$

Let $G = (V, \Sigma, S, P)$ be a context-free grammar.

The nondeterministic bottom-up PDA corresponding to G is

$NB(G) = (Q, \Sigma, \Gamma, q_0, Z_0, A, \delta)$, defined as follows:

Q contains the initial state q_0 , the state q_1 , and the (only) accepting state q_2 , together with other states to be described shortly.

$$\Gamma = V \cup \Sigma \cup \{Z_0\}$$

[M] D 5.22

Definition

The Nondeterministic Bottom-Up PDA $NB(G)$ (continued)

For every $\sigma \in \Sigma$ and every $X \in \Gamma$, $\delta(q_0, \sigma, X) = \{(q_0, \sigma X)\}$. This is a *shift* move.

For every production $B \rightarrow \alpha$ in G , and every nonnull string $\beta \in \Gamma^*$,
 $(q_0, \Lambda, \alpha^r \beta) \vdash^* (q_0, \Lambda, B\beta)$,

where this *reduction* is a sequence of one or more moves in which, if there is more than one, the intermediate configurations involve other states that are specific to this sequence and appear in no other moves of $NB(G)$.

One of the elements of $\delta(q_0, \Lambda, S)$ is (q_1, Λ) ,
and $\delta(q_1, \Lambda, Z_0) = \{(q_2, Z_0)\}$.

[M] D 5.22

Theorem

If G is a context-free grammar, then the nondeterministic bottom-up PDA $NB(G)$ accepts the language $L(G)$.

The details of the proof of this result do not have to be known for the exam.

[M] Th 5.23

Example: algebraic expressions

shift-reduce

post-order reduction \equiv rightmost derivation, bottom-up

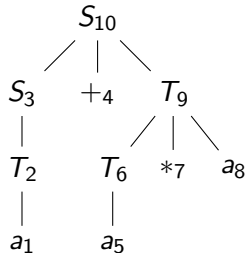

stack [reverse]

Z_0
 $Z_0 a_1$
 $Z_0 T_2$
 $Z_0 S_3$
 $Z_0 S_3 +4$
 $Z_0 S_3 +4 a_5$
 $Z_0 S_3 +4 T_6$
 $Z_0 S_3 +4 T_6 *7$
 $Z_0 S_3 +4 T_6 *7 a_8$
 $Z_0 S_3 +4 T_9$
 $Z_0 S_{10}$
 -

input

$a + a * a$
 $+ a * a$
 $+ a * a$
 $+ a * a$
 $a * a$
 $* a$
 $* a$
 a

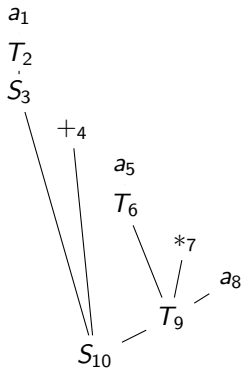

Due to Chomsky, Evey, and Schützenberger (1962/3).

Theorem

Context-free grammars and Pushdown automata are equivalent.

\leftrightarrow (1) PDA acceptance by empty stack

\leftrightarrow (2) triplet construction, CFG nonterminals $[p, A, q]$ for PDA computations

REFERENCES

N. Chomsky. Context-free grammars and push-down storage. Quarterly Progress Report No. 65, Research Laboratory of Electronics, M.I.T., Princeton, New Jersey (1962)

R.J. Evey. The theory and application of pushdown store machines. In *Mathematical Linguistics and Automatic Translation*, NSF-IO, pages 217–255. Harvard University, May 1963,
and

M. P. Schützenberger. On context-free languages and pushdown automata. *Inform. and Control*, 6:217–255, 1963. doi:[10.1016/S0019-9958\(63\)90306-1](https://doi.org/10.1016/S0019-9958(63)90306-1)

From lecture 10:

$$M = (Q, \Sigma, \Gamma, q_0, Z_0, A, \delta)$$

configuration (q, x, α) $q \in Q, x \in \Sigma^*, \alpha \in \Gamma^*$

state, remaining input, stack with top left

$$\begin{array}{ccccc} \text{step } (p, ax, B\alpha) \vdash_M (q, x, \beta\alpha) & \text{when } (q, \beta) \in \delta(p, a, B) \\ \vdash_M^n & \vdash_M^* & \vdash & \vdash^n & \vdash^* \end{array}$$

Definition

String x accepted by M (by *final state*), if

$(q_0, x, Z_0) \vdash^* (q, \Lambda, \alpha)$ for some $q \in A$, and some $\alpha \in \Gamma^*$

Language accepted by M (by *final state*)

$$L(M) = \{ x \in \Sigma^* \mid x \text{ accepted by } M \}$$

read complete input, end in accepting state, **some path**

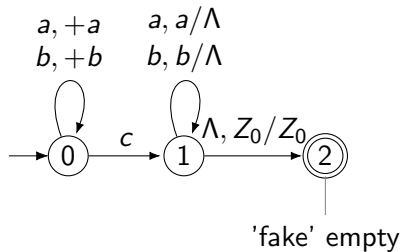

check state

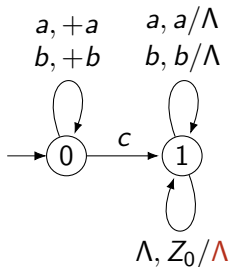

check stack

ABOVE

On many cases the PDA moves to the accepting state after checking that the stack is empty, when the topmost symbol is a special Z_0 that always has been at the bottom of the stack.

It is more natural to accept directly by looking at the stack rather than by looking at the state. This leads to the notion of the *empty stack* language of a PDA.

$$M = (Q, \Sigma, \Gamma, q_0, Z_0, A, \delta)$$

Definition

Language accepted by M by *empty stack*

$$L_e(M) = \{ x \in \Sigma^* \mid (q_0, x, Z_0) \vdash^* (q, \Lambda, \Lambda) \text{ for some state } q \in Q \}$$

[M] D 5.27

Theorem

If M is a PDA then there is a PDA M_1 such that $L_e(M_1) = L(M)$.

Sketch of proof...

[M] Th 5.28

Simulate $M = (Q, \Sigma, \Gamma, q_0, Z_0, A, \delta)$

- Simulate $M = (Q, \Sigma, \Gamma, q_0, Z_0, A, \delta)$
- empty stack 'at' final state
 - prohibit early empty stack

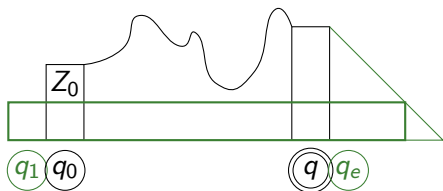

Construction PDA $M_1 = (Q_1, \Sigma, \Gamma_1, q_1, Z_1, A_1, \delta_1)$ such that $L_e(M_1) = L(M)$

- $Q_1 = Q \cup \{q_1, q_e\}$
- $\Gamma_1 = \Gamma \cup \{Z_1\}$
- new instructions:

$$\delta_1(q_1, \Lambda, Z_1) = \{(q_0, Z_0 Z_1)\}$$

$$\delta_1(q, \Lambda, X) \ni (q_e, X) \text{ for } q \in A, \text{ and } X \in \Gamma_1$$

$$\delta_1(q_e, \Lambda, X) = \{(q_e, \Lambda)\} \text{ for } X \in \Gamma_1$$

$A \rightarrow \alpha \in P, a \in \Sigma$

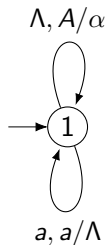
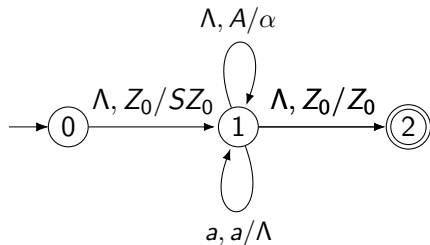

Theorem

For every CFL L there exists a single state PDA M such that $L_e(M) = L$.

ABOVE

Now that we have empty stack acceptance we can reconsider the expand-match technique. In fact we do not need two extra states to introduce a bottom of stack symbol, and can make a single state PDA.

BELOW

The expand-match method can be used for any CFG. If we slightly restrict the grammars, we can combine each match with the expand step just before, that introduced the terminal. This gives a very direct translation between grammar and its leftmost derivation, and a single state PDA and its computation.

On this normal form each production is of the form $A \rightarrow a\alpha$, where $a \in \Sigma \cup \{\Lambda\}$ can be the only terminal at the right. That means that any terminal pushed on the stack will be on top, and immediately will be matched.

$\text{cfg } G \iff \text{1-pda } M$
 $A \rightarrow \alpha \quad \delta(-, \Lambda, A) \ni (-, \alpha) \quad \text{expand}$
 $\delta(-, a, a) = \{(-, \Lambda)\} \quad \text{match}$

normal form $\alpha \in (\Sigma \cup \{\Lambda\}) \cdot V^*$
 $A \rightarrow a\alpha \quad \delta(-, a, A) \ni (-, \alpha) \quad \text{combined}$

SimplePal: $S \rightarrow aSA \mid bSB \mid c \quad A \rightarrow a \quad B \rightarrow b$

leftmost derivation \iff computation

S	\vdash	$(-, \text{abbcbba}, S)$
$\Rightarrow aSA$	\vdash	$(-, \text{bcbba}, SA)$
$\Rightarrow abSBA$	\vdash	$(-, \text{cbba}, SBA)$
$\Rightarrow abbSBBA$	\vdash	$(-, \text{bba}, SBBA)$
$\Rightarrow abbcBBA$	\vdash	$(-, \text{ba}, BBA)$
$\Rightarrow abbcbaBA$	\vdash	$(-, a, BA)$
$\Rightarrow abbcbbA$	\vdash	$(-, \Lambda, A)$
$\Rightarrow abbcbb\Lambda$	\vdash	$(-, \Lambda, \Lambda)$

In this case: deterministic PDA

Theorem

If $L = L_e(M)$ is the empty stack language of PDA M , then there exists a CFG G such that $L = L(G)$.

[M] Th 5.29

$$M = (Q, \Sigma, \Gamma, q_0, Z_0, A, \delta)$$

Theorem

If $L = L_e(M)$ is the empty stack language of PDA M , then there exists a CFG G such that $L = L(G)$.

[M] Th 5.29

$$M = (Q, \Sigma, \Gamma, q_0, Z_0, A, \delta)$$

triplet construction

nonterminals $[p, A, q]$ $p, q \in Q, A \in \Gamma$
 $[p, A, q] \Rightarrow_G^* w$ iff $(p, w, A) \vdash_M^* (q, \Lambda, \Lambda)$

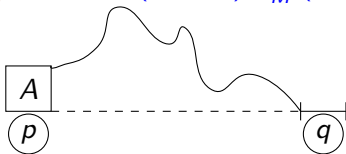

- nonterminals $[p, A, q]$ $p, q \in Q, A \in \Gamma$
 $[p, A, q] \Rightarrow_G^* w$ iff $(p, w, A) \vdash_M^* (q, \Lambda, \Lambda)$

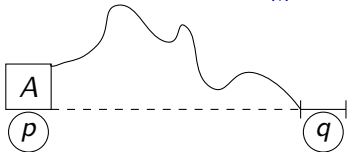

- productions $S \rightarrow [q_0, Z_0, q]$ for all $q \in Q$

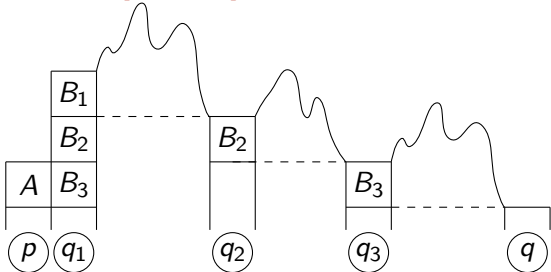

- $[p, A, q] \rightarrow \sigma [q_1, B_1, q_2][q_2, B_2, q_3] \cdots [q_n, B_n, q]$
 for $(q_1, B_1 \cdots B_n) \in \delta(p, \sigma, A)$, and $q, q_2, \dots, q_n \in Q$
- $[p, A, q] \rightarrow \sigma$ for $(q, \Lambda) \in \delta(p, \sigma, A)$

N.B.: σ may also be Λ

Construction from PDA to CFG, and the intuition behind it, must be known for the exam.

The details of the proof that $L(G) = L_e(M)$ do not have to be known for the exam.

$$L_e(M) = \text{SimplePal} = \{ w c w^r \mid w \in \{a, b\}^* \}$$

12 transitions \Rightarrow 33 (+2) productions (!)

$$X \in \{A, B, Z_0\}$$

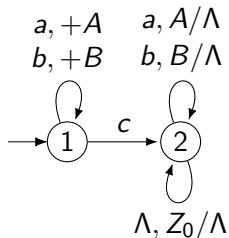

$$\delta(1, a, X) = \{(1, AX)\}$$

$$\delta(1, b, X) = \{(1, BX)\}$$

$$\delta(1, c, X) = \{(2, X)\}$$

$$\delta(2, a, A) = \{(2, \Lambda)\}$$

$$\delta(2, b, B) = \{(2, \Lambda)\}$$

$$\delta(2, \Lambda, Z_0) = \{(2, \Lambda)\}$$

$$S \rightarrow [1, Z_0, 1] \mid [1, Z_0, 2]$$

$$[1, X, 1] \rightarrow a [1, A, 1][1, X, 1]$$

$$[1, X, 1] \rightarrow a [1, A, 2][2, X, 1]$$

$$[1, X, 2] \rightarrow a [1, A, 1][1, X, 2]$$

$$[1, X, 2] \rightarrow a [1, A, 2][2, X, 2]$$

...

$$[1, X, 1] \rightarrow c [2, X, 1]$$

$$[1, X, 2] \rightarrow c [2, X, 2]$$

$$[2, A, 2] \rightarrow a$$

$$[2, B, 2] \rightarrow b$$

$$[2, Z_0, 2] \rightarrow \Lambda$$

not 'live'

From lecture 11:

$$\text{AeqB} = \{ x \in \{a, b\}^* \mid n_a(x) = n_b(x) \}$$

$$S \rightarrow \Lambda \mid aB \mid bA$$

$$A \rightarrow aS \mid bAA$$

$$B \rightarrow bS \mid aBB$$

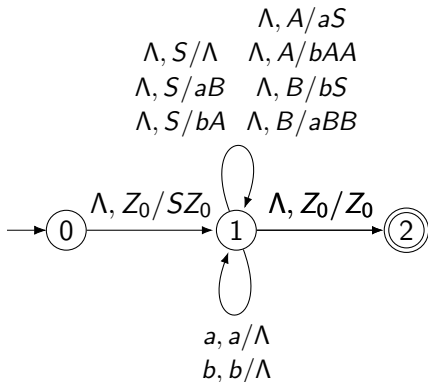

5.5. Parsing: make PDA (more) deterministic by looking ahead one symbol in input.

See Compiler Construction